

ITEM NUMBER	LENGTH
TS187-100-0313	0.313"
TS187-100-0375	0.375"
TS187-100-0438	0.438"
TS187-100-0500	0.500"
TS187-100-0625	0.625"
TS187-100-0750	0.750"
TS187-100-1000	1.00"
TS187-100-1125	1.11"
TS187-100-1250	1.25"
TS187-100-1500	1.50"
TS187-100-1750	1.75"
TS187-100-2000	2.00"
TS187-100-2125	2.13"
TS187-100-2250	2.23"
TS187-100-2500	2.50"
TS187-100-2750	2.75"
TS187-100-3000	3.00"
TS187-100-3125	3.13"
TS187-100-3250	3.25"
TS187-100-3500	3.50"
TS187-100-3750	3.75"
TS187-100-4000	4.00"
TS187-100-6000	6.00"

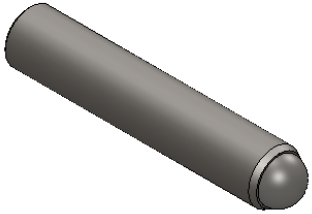
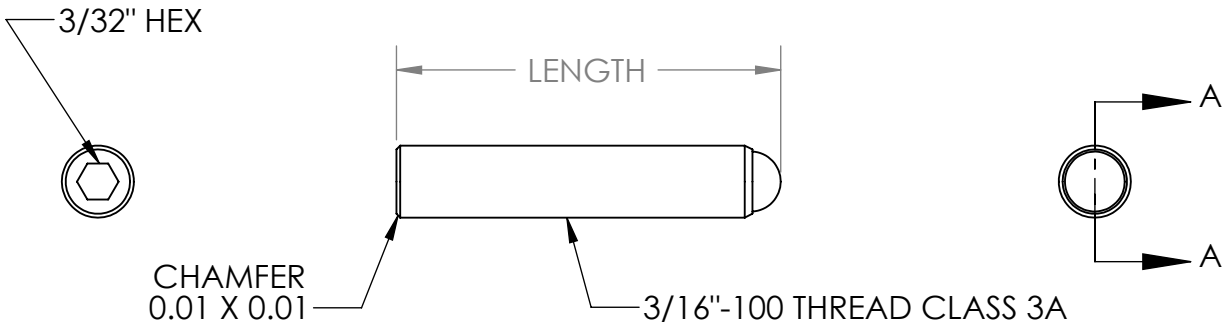
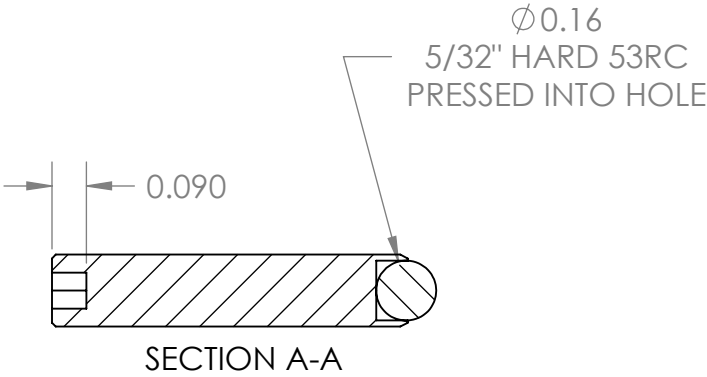

FOR INFORMATION ONLY
NOT FOR MANUFACTURING
ITEM / DRAWING IS SUBJECT TO CHANGES WITOUT NOTIFICATION

	NAME	DATE	BASE OPTICS LLC		
DRAWN	LS	12/28/11			
APPROVED	GE	01/10/12	TITLE:		
MATERIAL			3/16"-100 FINE ADJUSTER SCREW		
18-8 (303)					
FINISH			SIZE	ITEM NO.	REV
N/A			A	TS187-XXXX	A
NOTE			SCALE: 2:1	WEIGHT: N/A lbs	SHEET 1 OF 1
BETTER THAN CLASS 3			COPYRIGHT © 2012 BY BASE OPTICS		